

JUXTA W Series General Specification

Model WX1□-LG (Variable software type)
WX2□-LG (Fixed software type)
1st-order Lag Unit

JUXTA

1. GENERAL

This is a variable or fixed software type computing unit which accepts a voltage signal from various converters and outputs the 1st-order lag computed result using a time constant set by a handy terminal or variable resistor as an isolated DC voltage or current signal.

2. SPECIFICATIONS

Model No.	WX1A-LG, WX1V-LG	WX2A-LG, WX2V-LG
Input signal	DC voltage signal: 1 point	DC voltage signal: 1 point Volume setting
Measuring range	0 to 10 V DC (Measuring span: More than 2 V) (*1)	
Input resistance	1 MΩ (At power failure: More than 100 KΩ)	
Output signal	4 to 20 mA, 2 to 10 mA, 1 to 5 mA, 0 to 20 mA, 0 to 16 mA, 0 to 10 mA or 0 to 1 mA DC 0 to 10 mV, 0 to 100 mV, 0 to 1 V, 0 to 10 V, 0 to 5 V, 1 to 5 V or -10 to +10 V DC	
Computing equation	$Y = \frac{1}{1+TS} X$ Y: Output signal X: Input signal (%) T: Time constant (sec)	
Time constant setting range	1.0 to 799.0 sec (1.0 to 799.0%) (*2)	1.0 to 100.0 sec (0.010 to 1.000 V)
Basic accuracy	±0.1% of measuring span	±0.2% of measuring span
Signal insulation	Between any of input signal, output signal, power supply circuits and grounding	
Insulation resistance	Between any of input, output and power (DC driven) Between any of input, output, power and grounding (AC driven) 100 MΩ/500 V DC	
Dielectric strength	Between input and output/power: 1500 V AC/min. and between output and power: 500 V AC/min. (DC driven) Between any of input, output, power and grounding: 1500 V AC/min. (AC driven)	
Power supply voltage	85 to 264 V AC 47 to 63 Hz, or 24 V DC ±10%	
Ambient temperature/humidity	0 to 50°C (32 to 122°F) and 5 to 93% relative humidity (No condensation)	
Effect of ambient temperature	±0.2% of span for 10°C (50°F) change	
Effect of power supply voltage	±0.1% of span for 85 to 264 V AC or 24 V DC ±10% variation	±0.2% of span for 85 to 264 V AC or 24 V DC ±10% variation
Power consumption	100 V AC, 7.0 VA (voltage output) and 100 V AC, 8.5 VA (current output) 24 V DC, 60 mA (voltage output) and 24 V DC, 82 mA (current output)	
Dimensions	72 (2.83") H × 48 (1.89") W × 127 (5.00") D mm (inch)	
Weight	Approx. 150 g (DC driven), 280 g (AC driven)	
Accessories	Tag number label: 1 sheet Mounting blocks: 2 pcs.	

Specify the following:

(*1) Measuring range from □ to □V

(*2) 1st-order lag time constant: □sec

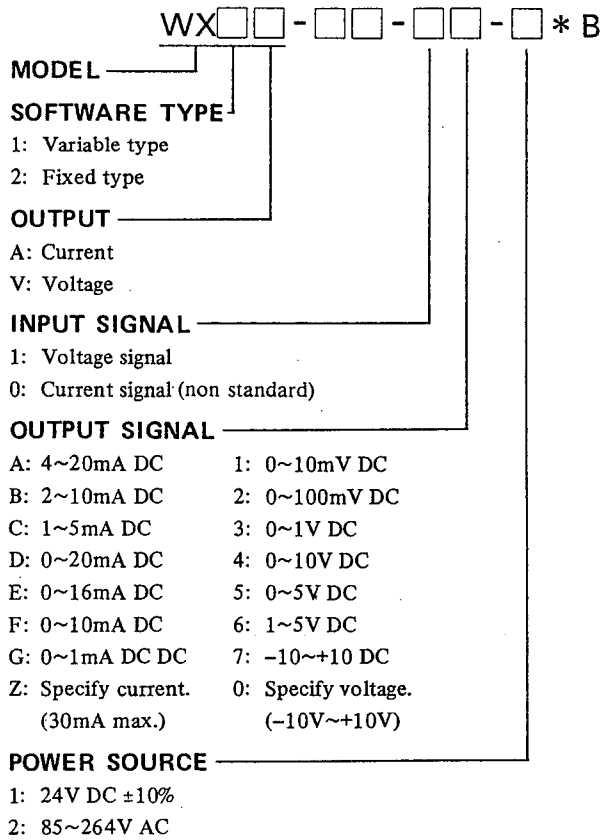

Ordering Information

Measuring Range of Input	
Voltage input signal: 2V min. Span for 0~10V DC Current input signal (input resist. 250Ω): (250Ω) × (Input current) shall be within the measuring span of voltage input signal.	
	Recommended Range
Current signal	4~20mA DC 2~10mA DC 0~20mA DC 0~16mA DC 0~10mA DC
Voltage signal	0~10V DC 0~ 5V DC 1~ 5V DC

(Note) Change of input between voltage and current is impossible by Handy Terminal.

OUTPUT RESISTANCE AND LOAD RESISTANCE

Output Signal	Load Resistance	Output Impedance
4 to 20mA DC	0 to 750Ω	5MΩ or more
2 to 10mA DC	0 to 1500Ω	
1 to 5mA DC	0 to 3000Ω	
0 to 20mA DC	0 to 750Ω	
0 to 16mA DC	0 to 900Ω	
0 to 10mA DC	0 to 1500Ω	
0 to 1mA DC	0 to 15kΩ	

Output Signal	Load Resistance	Output Impedance
0 to 10mV DC	100kΩ or more	100Ω or less
0 to 100mV DC		
0 to 1V DC	2kΩ or more	1Ω or less
0 to 5V DC		
1 to 5V DC		
0 to 10V DC	10kΩ or more	
-10 to +10V DC		

Subject to change without notice for grade up quality and performance